INTRODUCTION

Infader

DIGITAL DJ MIXING SYSTEM

Thank you for purchasing the RED Sound INFADER digital DJ mixing desk.

Digital technology is revolutionizing the world around us: digital audio, digital video, digital television, digital radio - in all these fields digital technology is expanding our ideas of what is possible. Digital Signal Processing has already delivered many of the technological innovations in audio which have driven the recording and re-mixing of dance music. Sampling and effects processing are major parts of the re-mix process and many styles of dance music just wouldn't have evolved without them. But up until now, the DJ has had to make do with the limitations of analogue technology in the live arena.

Now, with INFADER, prepare to have your pre-conceptions of what a DJ Mixer can be blown away. Used to a simple cross-fader? Or three kill switches for High, Mid and Low? Then how does a separate crossfader for High, Mid and Low sound. Imagine being able to independently mix between the three separate frequency bands of your source tracks, a feature so revolutionary Red Sound has patented it.

And the Tri-Fader Module is just the first of the digital innovations which Red Sound are developing to bring the benefits of digital technology to live mixing. As the INFADER Digital DJ Mixing System expands, other exciting new methods of processing the sound in live mixing will be added to the DJ's arsenal.

But INFADER already gives you three times the creativity of the conventional crossfader.

Let INFADER triple your mixing potential today.

TOP PANEL

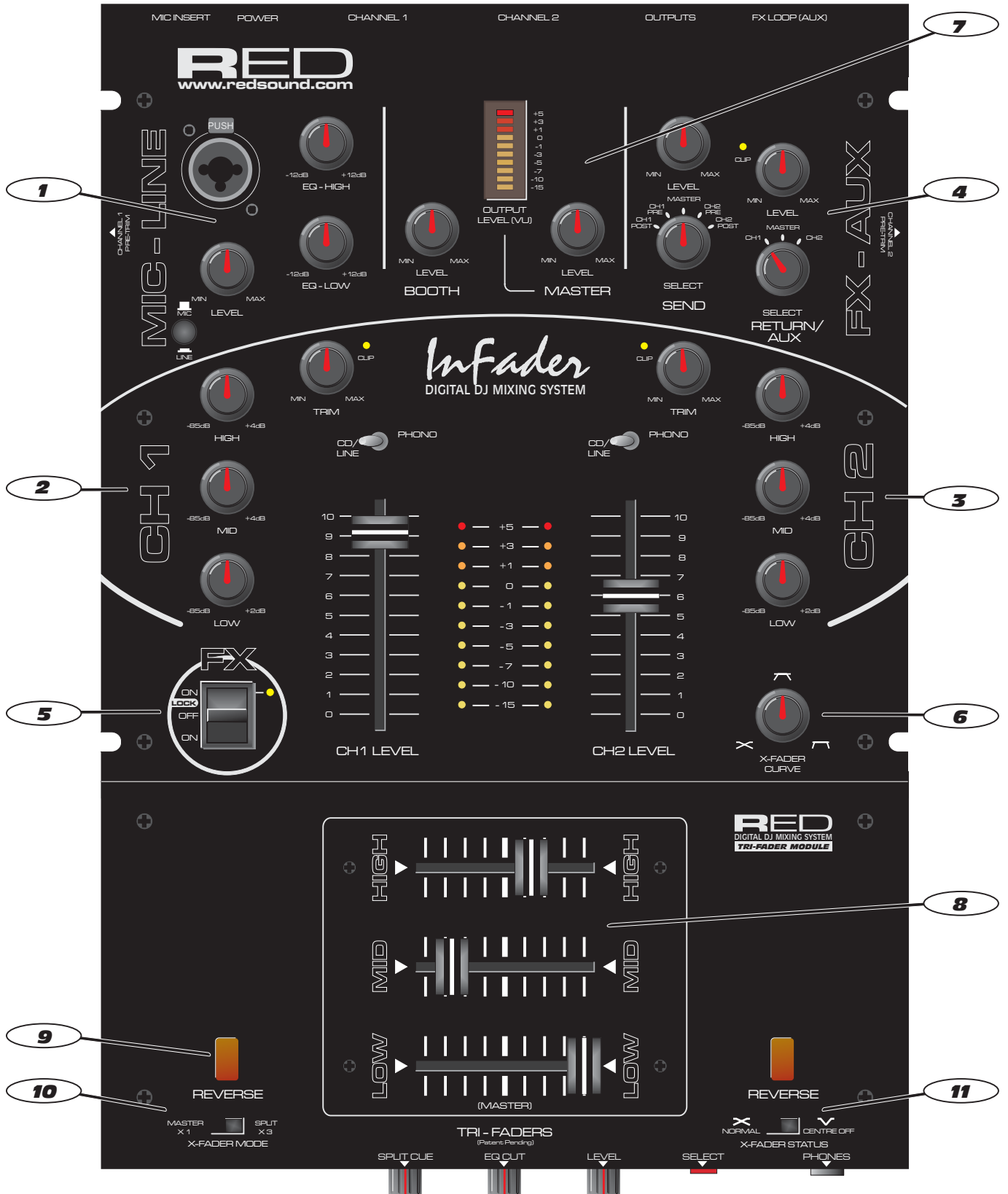

FRONT PANEL FEATURES

- 1. MIC/LINE INPUT:** This section features [LEVEL], [EQ-HIGH] and [EQ-LOW] controls for the selectable microphone/line level input stage. The [MIC/LINE] push-button switch selects the input type. The combi-XLR connector accepts XLR connectors for microphone use and ¼ Jack plugs for mono line level devices (CD/tape players, drum machines, synthesizers etc.)
- 2. CHANNEL 1 INPUT:** This section features [TRIM], [INPUT SELECT], [LEVEL], [EQ-LOW], [EQ-MID] and [EQ-HIGH] controls for the channel 1 input stage. The [PRE-TRIM] control for this channel is situated on the left-hand side panel. The bi-colour [CLIP] indicator shows the pre-A-to-D convertor level status. The 10-way indicator shows channel level with 2 second peak-hold feature. This channel can be used with any CD/line or Phono level input device.
- 3. CHANNEL 2 INPUT:** This section features [TRIM], [INPUT SELECT], [LEVEL], [EQ-LOW], [EQ-MID] and [EQ-HIGH] controls for the channel 2 input stage. The [PRE-TRIM] control for this channel is situated on the right-hand side panel. The bi-colour [CLIP] indicator shows the pre-A-to-D convertor level status. The 10-way indicator shows channel level with 2 second peak-hold feature. This channel can be used with any CD/line or Phono level input device.
- 4. FX SEND/RETURN - AUXILIARY INPUT:** This section features [SEND LEVEL], [SEND SELECT], [RETURN /AUX LEVEL] and [RETURN/AUX SELECT] controls for the effects loop/auxiliary input stage. The bi-colour [CLIP] indicator shows the pre-A/D convertor level status for the effects return/auxiliary input. The RETURN/AUX channel can be used with any CD/line level input device.
- 5. FX ON/OFF SWITCH:** This 3-way 'paddle' switch controls the effect send/return loop.
- 6. X- FADER CURVE:** This control allows you to adjust the characteristics of the crossfader curve.
- 7. MASTER/BOOTH OUTPUT:** This section features the [MASTER LEVEL] and [BOOTH LEVEL] controls. The 10-way VU indicator shows the MASTER output level.
- 8. TRI-FADERS:** This section features the [LOW/MASTER], [MID] and [HIGH] fader controls.
- 9. REVERSE:** The two [REVERSE] buttons are connected in parallel. When either button is pressed, the current fader position(s) will be automatically reversed.
- 10. X- FADER MODE:** This 2-way switch selects between [MASTERx1] mode (single crossfader operation) and [SPLITx3] mode (3-way crossfading).
- 11. X- FADER STATUS:** This 2-way switch selects between [NORMAL] status (fader in centre position = CH1, CH2 sound ON) and [CENTRE OFF] status (fader in centre position = CH1, CH2 sound OFF).

REAR PANEL

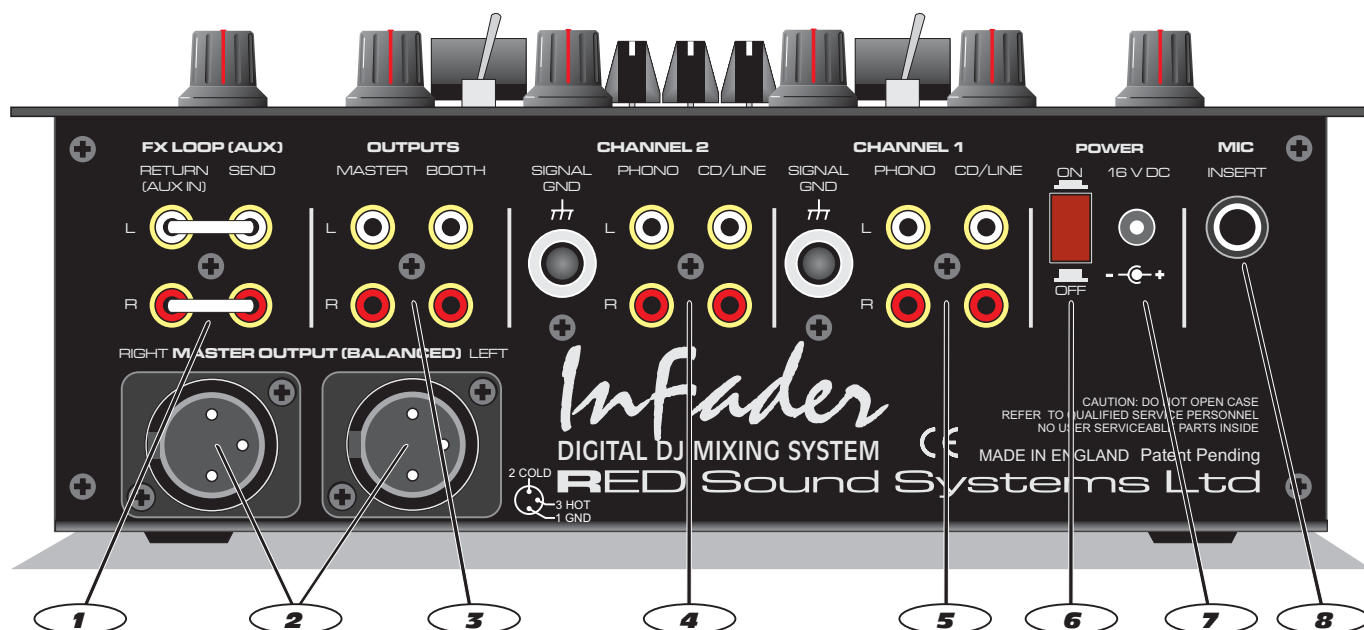

1. FX LOOP [AUX] - RCA Phono Connectors

Use these sockets to connect any external effects processor to INFADER. Alternatively, you can use the [RETURN/AUX IN] sockets to connect an additional stereo CD/line level sound source to INFADER for multi-channel operation whilst using the [SEND] connectors as a RECORD out. INFADER is shipped with shorting bars fitted between the send and return sockets to avoid 'no output' conditions when the front panel 'FX' switch is set to on.

2. BALANCED MASTER OUTPUTS - XLR Connectors

Use these sockets to connect INFADER to amplification systems supporting balanced XLR input.

3. OUTPUTS - RCA Phono Connectors

Use the sockets marked [MASTER] to connect INFADER to amplification systems supporting unbalanced RCA input. Use the sockets marked [BOOTH] to connect INFADER to the monitor amplification system.

4. CHANNEL 2 - RCA Phono Connectors/Earth Terminal

Use the sockets marked [PHONO] and [SIGNAL GND] to connect the analog turntable to channel 2. Use the sockets marked [CD/LINE] to connect the CD or line level audio player to channel 2.

5. CHANNEL 1 - RCA Phono Connectors/Earth Terminal

Use the sockets marked [PHONO] and [SIGNAL GND] to connect the analog turntable to channel 1. Use the sockets marked [CD/LINE] to connect the CD or line level audio player to channel 1.

6. POWER - Switch

This turns the power on and off.

7. DC POWER IN - Connector

IMPORTANT: Only use the 16vDC 750 mA PSU supplied with INFADER to power the unit.

8. MIC INSERT - ¼ Jack Connector

Use this socket to send/return the MIC/LINE channel signal to an external sound processor.

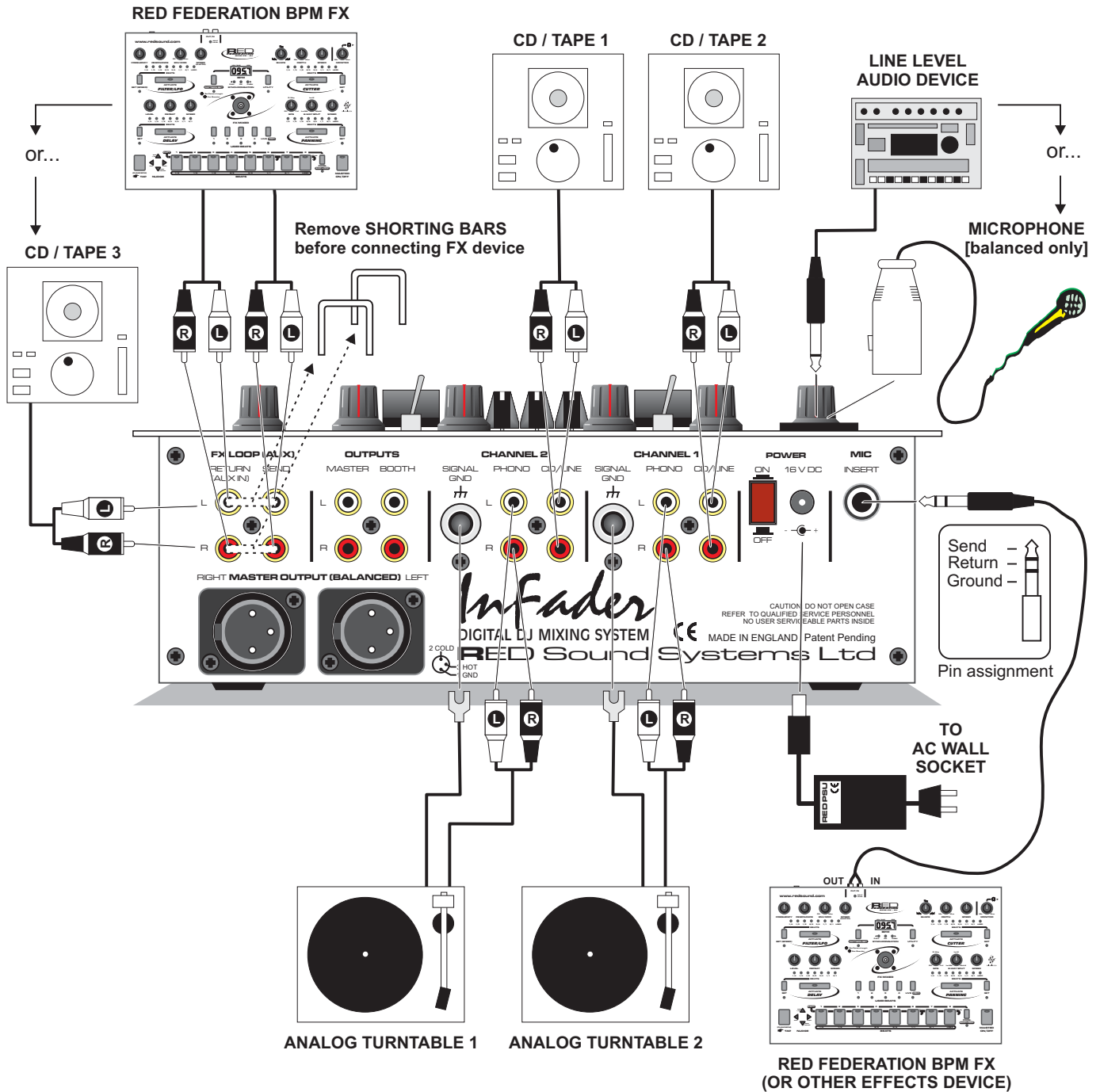

OUTPUT CONNECTIONS

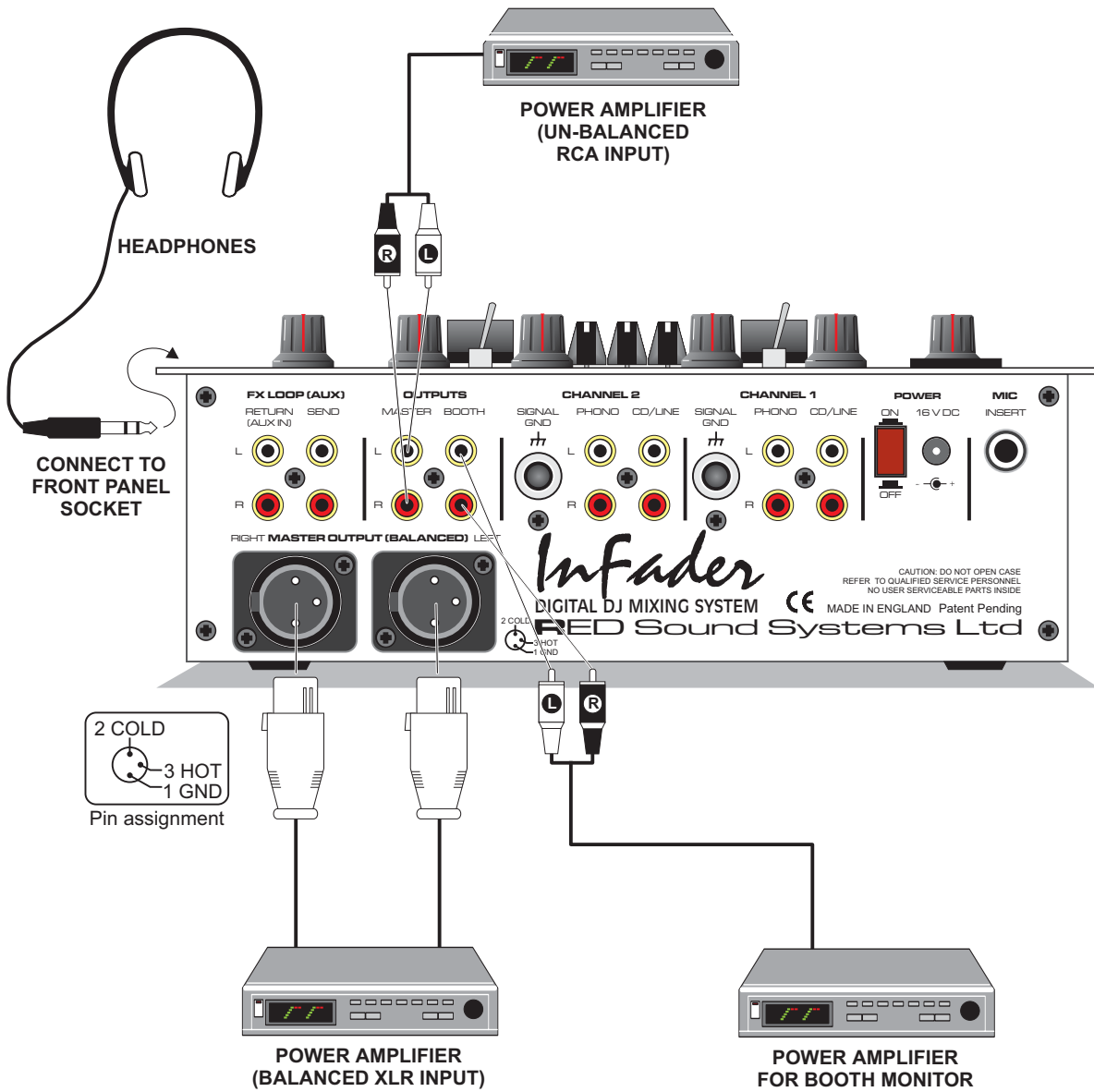

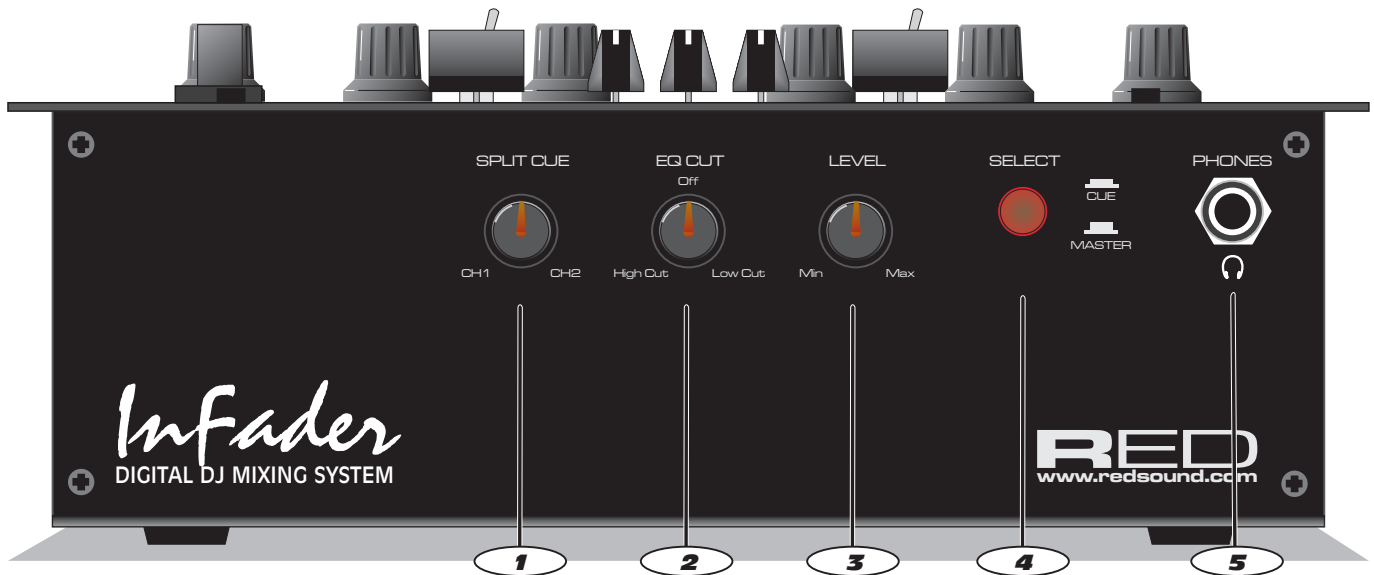

The front panel contains the following monitor controls:

1. SPLIT CUE - Rotary

This control allows you to monitor channel 1, channel 2 or a mix of both when [SELECT] is set to CUE.

2. EQ CUT - Rotary

This control can be used to change the CUE monitor EQ. To the left, high frequencies are cut and to the right, low frequencies are cut.

3. LEVEL - Rotary

This control sets the audio level to the connected headphones.

4. SELECT - Pushbutton

This switch allows you to select MASTER or CUE monitoring.

5. HEADPHONE OUT - Jack connector

Connect the ¼ jack plug from your headphones to this connector.

GETTING STARTED

Before use, please observe the following guidelines:

CONNECTIONS: Before making any connections, make sure that the power on all your equipment is turned OFF. Connect the power supply (included) to the 'power in' socket on the rear panel of INFADER and plug it into a suitable AC outlet. Connect the audio cables for a typical system setup as shown on pages 5/6.

TURNING ON THE POWER: Make sure all connections have been made correctly and the volume controls on INFADER and the amplifier system are turned completely down. Press IN the rear panel power switch on INFADER. Turn ON the power to the connected CD/analog players and amplifier system.

POWER ON INDICATION: When INFADER is powered up the [FX ON/OFF] indicator flashes to indicate that power is switched on. If this does not happen, check the power supply is of the correct type and the unit is switched on and correctly connected.

INFADER is now ready for use.

MIC / LINE INPUT

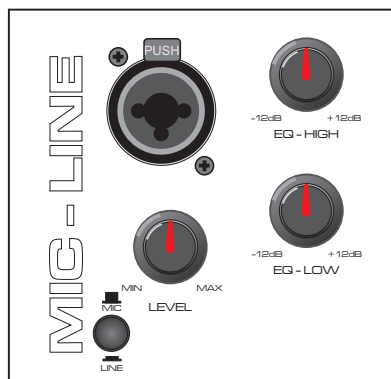

This section of INFADER features controls and connectors for the DJ microphone. The circuitry is totally analog and is fed directly to the master output buss (also analog). The combination XLR/Jack connector allows you to use this input as a 4th line-level input, ideal for introducing a further CD/tape player or other sound source such as MIDI synthesizer/sequencer.

COMBI XLR CONNECTOR

This connector accepts the standard XLR plug fitted to BALANCED microphone cables. Before attempting to connect the microphone, first ensure the [LEVEL] control is set to minimum and the [MIC/LINE] switch is set to the [MIC] position (UP). Align the three pins on the plug with those on the socket and then push home fully until the retaining latch clicks into place. To disconnect the microphone, first press down the retaining tab labelled [PUSH] and then gently pull out the XLR microphone plug.

The centre area of this connector also accepts a standard 1/4" jack plug for connecting line-level devices. Only mono signals can be routed through this section. If a stereo 1/4" jack plug is inserted, the left/right channels will be summed. Before attempting to connect the line-level device, first ensure the [LEVEL] control is set to minimum and the [MIC/LINE] switch is set to the [LINE] position (DOWN). Push in the jack plug until it snaps into place. There is no locking facility for this type of connector.

LEVEL CONTROL

This control sets the input level for the microphone or line-level device. At the fully anti-clockwise position there will be no sound. As the control is moved in a clockwise direction the level will be gradually increased until, at the fully clockwise position, the level will be at its maximum.

CARE!: This signal is routed to the master buss POST [MASTER] level control - e.g. the output level of the microphone or line-level device will be un-affected by the [MASTER] level control.

EQ - LOW CONTROL

This control adjusts the bass equalisation of the microphone/line-level sound. At the 12 o'clock, centre click position the low EQ will be flat (no cut or boost). As the control is moved anti-clockwise the low frequencies will be progressively cut until, at the fully anti-clockwise position the maximum low frequency cut will be applied (-12dB). As the control is moved clockwise from the centre position the low frequencies will be progressively boosted until, at the fully clockwise position the maximum low frequency boost will be applied (+12dB@100Hz).

EQ - HIGH CONTROL

This control adjusts the treble equalisation of the microphone or line-level sound. At the 12 o'clock, centre click position the high EQ will be flat (no cut or boost). As the control is moved anti-clockwise the high frequencies will be progressively cut until, at the fully anti-clockwise position the maximum high frequency cut will be applied (-12dB). As the control is moved clockwise from the centre position the high frequencies will be progressively boosted until, at the fully clockwise position the maximum high frequency boost will be applied (+12dB@10kHz).

MIC/LINE SWITCH

This push button switch selects the input level sensitivity. When set to the [MIC] position (UP), the XLR part of the input connector will be active. When set to the [LINE] position (DOWN), the 1/4" Jack part of the input connector will be active.

MIC INSERT CONNECTOR (REAR PANEL)

This 1/4" jack rear panel connector can be used to route the microphone or line-level signal through an external effects processor. Using a suitable cable (see page 5 for pin allocation), connect this socket to the in/outs of the effects device to add reverb/echo or more extreme effects (RED - FEDERATION or XS-FX) to the sound.

INPUT CHANNELS 1&2

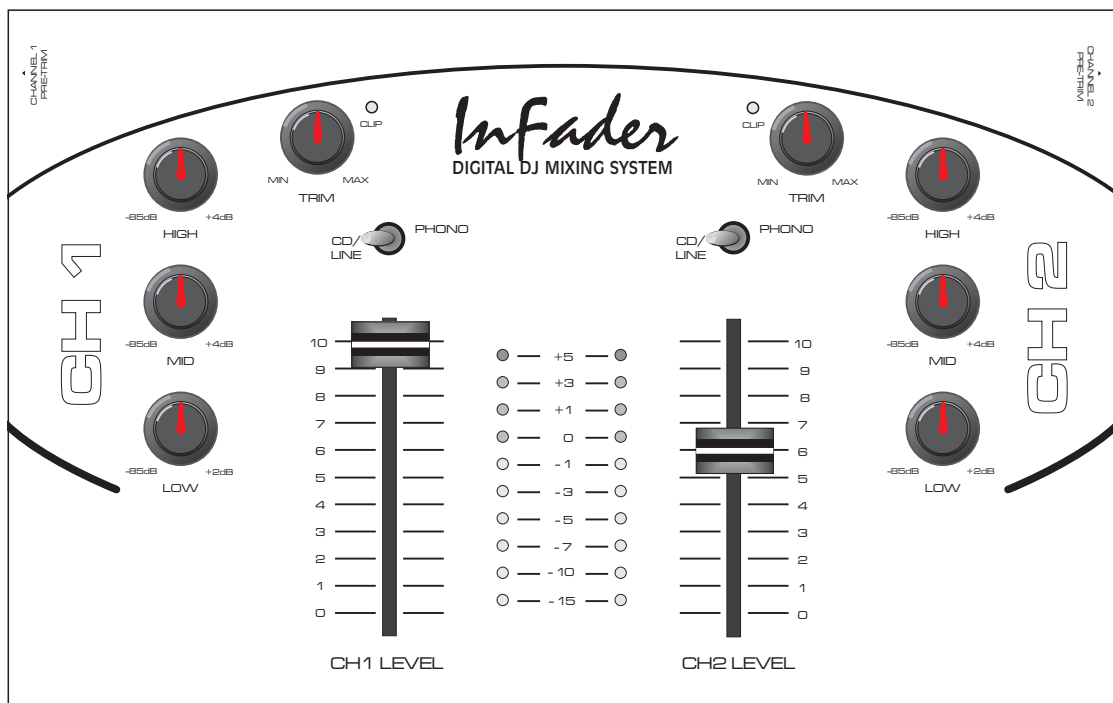

This section of INFADER features all the main controls for input channels 1 and 2, most of which come under the control of the digital signal processor (DSP). The EQ sections in both channels are totally created within the DSP which enables INFADER to deliver an amazing -85dB of cut whilst, for professional considerations limiting the boost to just +2/4dB. The level faders are also digitally controlled which assures extra long-life for these hard-working components.

INPUT SELECTOR SWITCHES

These 2-way toggle switches select the connected playback device for each channel. In the left-hand position the [CD/LINE] input will be selected. In the right-hand position the [PHONO] analog input will be selected.

TRIM CONTROLS

These controls adjust the gain of the input signal. At the 12 o'clock position the gain will be 0dB. As the control is moved anti-clockwise the gain will be progressively reduced until, at the fully anti-clockwise position the signal will be at infinity (∞) or off. As the control is moved clockwise from the centre position the gain will be progressively increased until, at the fully clockwise position the maximum gain setting will be applied (+6dB).

CLIP INDICATORS - The bi-colour [CLIP] indicators are used to detect overload conditions in the gain section before the A/D convertors. When a good signal level is detected, the indicator will light GREEN. When the signal level becomes too high for the A/D convertor the indicator will change colour to RED and the audio sound will become distorted. If this occurs, back-off the [TRIM] control until a GREEN indication (with occasional RED flashes) is shown.

PRE-TRIM CONTROLS

These controls are situated on the side panels (channel 1 on LEFT side panel / channel 2 on RIGHT side panel). They can be used to attenuate the input signal level prior to the main [TRIM] control to avoid overload conditions. These controls are factory set to maximum gain (fully clockwise) for professional use. When using high output playback devices it may be necessary to back-off the [PRE-TRIM] gain to stop the input channel from overloading.

To change the [PRE-TRIM] setting, use a small flat-bladed screwdriver to adjust the potentiometers, as shown below:

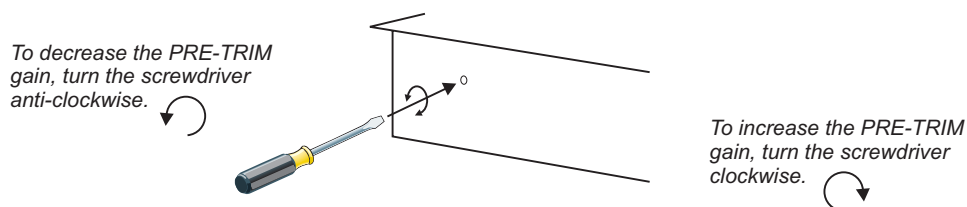

CHANNEL VOLUME FADERS

These 60mm travel faders are digitally controlled by the DSP and are used to adjust the volume of CH1 and CH2.

PEAK LEVEL METER

These indicators show the signal level pre-channel faders and cover a range of -15dB to +5dB. The peak hold feature shows peak level indications for approximately 2 seconds. The indicators from -15 to 0dB are coloured green. Indicators +1dB and +3dB are amber whilst the +5dB indicator is coloured red.

HIGH EQ

These controls adjust the high tone characteristics of the CH1 / CH2 inputs. At the 12 o'clock, centre click position the high EQ will be flat (no cut or boost). As the control is moved anti-clockwise the high frequencies will be progressively cut until, at the fully anti-clockwise position the maximum high frequency cut will be applied (-85dB). As the control is moved clockwise from the centre position the high frequencies will be progressively boosted until, at the fully clockwise position, the maximum high frequency boost will be applied (+4dB@10kHz).

MID EQ

These controls adjust the mid tone characteristics of the CH1 / CH2 inputs. At the 12 o'clock, centre click position the mid EQ will be flat (no cut or boost). As the control is moved anti-clockwise the mid frequencies will be progressively cut until, at the fully anti-clockwise position the maximum mid frequency cut will be applied (-85dB). As the control is moved clockwise from the centre position the mid frequencies will be progressively boosted until, at the fully clockwise position, the maximum mid frequency boost will be applied (+4dB@1kHz).

LOW EQ

These controls adjust the low tone characteristics of the CH1 / CH2 inputs. At the 12 o'clock, centre click position the low EQ will be flat (no cut or boost). As the control is moved anti-clockwise the low frequencies will be progressively cut until, at the fully anti-clockwise position the maximum low frequency cut will be applied (-85dB). As the control is moved clockwise from the centre position the low frequencies will be progressively boosted until, at the fully clockwise position, the maximum low frequency boost will be applied (+2dB@100Hz).

FX SEND & RETURN - AUX

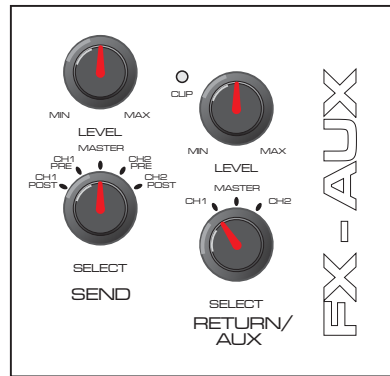

This section of INFADER features controls for the effects send/return loop, which can also be used as an auxiliary input/record output. The routing switches are controlled by the DSP for comprehensive send and return patching. For example, you can take the CH1 input signal (before or after the crossfaders) and route it through an external effects device before bringing it back via CH1, CH2 or Master buss. If effects are not required you can connect a line-level playback device to the return side for expanded input channel capability whilst recording a performance from the send output. *When there are NO devices connected to these terminals we recommend that the supplied shorting bars are fitted to avoid 'no output' conditions if the FX switch is accidentally set to ON.*

SEND - LEVEL

This control sets the output level to the connected effects unit. At the fully anti-clockwise position there will be no output signal. As the control is moved in a clockwise direction the output level will be gradually increased until, at the fully clockwise position, the output level will be at its maximum. Use the input level indicator on your effects unit to monitor and set the correct input level.

NOTE: the [FX] switch must be turned ON to output the signal - see next page for further details).

SEND - SELECT

This control selects the signal source that will be sent to the external effects unit. There are five 'tap-off' points to choose from, as detailed below:

1. **CHANNEL 1 POST** - Only the CH1 signal will be transmitted, post-crossfaders (AFTER any crossfader filtering).
2. **CHANNEL 1 PRE** - Only the CH1 signal will be transmitted, pre-crossfaders (BEFORE any crossfader filtering).
3. **MASTER** - The master output signal will be transmitted (only MASTER RETURN can be selected for this setting).
4. **CHANNEL 2 PRE** - Only the CH2 signal will be transmitted, pre-crossfaders (BEFORE any crossfader filtering).
5. **CHANNEL 2 POST** - Only the CH2 signal will be transmitted, post-crossfaders (AFTER any crossfader filtering).

RETURN / AUX - LEVEL

This control sets the amount of signal coming back from the connected effects unit. At the fully anti-clockwise position there will be no sound. As the control is moved in a clockwise direction the input level will be gradually increased until, at the fully clockwise position, the input level will be at its maximum.

CLIP INDICATOR - The bi-colour [CLIP] indicator is used to detect overload conditions in the gain section before the A/D convertor. When a good signal level is detected, the indicator will light GREEN. When the level becomes too high for the A/D convertor, the indicator will change colour to RED and the audio sound will become distorted. If this occurs, back-off the [LEVEL] control until a GREEN indication (with occasional RED flashes) is shown.

RETURN - SELECT

This control selects the point at which the returning effects are re-introduced. There are three 'patch' points to choose from, as detailed over:

1. **CHANNEL 1** - The return signal will be routed directly to the CH1 buss (pre-channel volume fader).
2. **MASTER** - The return signal will be routed directly to the Master buss (pre-master volume fader).
3. **CHANNEL 2** - The return signal will be routed directly to the CH2 buss (pre-channel volume fader).

NOTE: When SEND [SELECT] is set to [MASTER], all three return settings will automatically be set to MASTER to prevent feedback loops occurring.

AUXILIARY IN - If effects are not required the RETURN section can be used as a third channel input. Simply connect the CD/tape player to the [RETURN / AUX IN] sockets and use the return [LEVEL] control to adjust the input level whilst observing the [CLIP] indicator. Select the desired signal routing with the return [SELECT] switch.

FX ON/OFF SWITCH

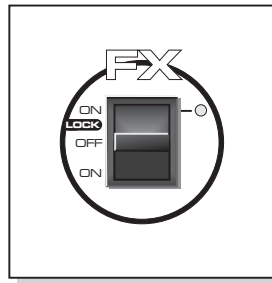

The performance 'paddle' type FX switch controls the ON/OFF status of the external effects. You can use the momentary ON position to flick-in effects 'on-the-fly' or use the locked-ON position for more sustained periods of externally processed sound.

When the [FX] switch is in the centre 'OFF' position there will be no output to the connected effects device. The indicator flashes in this mode to show that FX send is de-activated (and power is on).

When the [FX] switch is in the forward 'LOCK-ON' position the sound, as set by the SEND [SELECT] control, will be sent to the connected effects device. The indicator stays on in this mode to show that FX send is activated. When the [FX] switch is pulled and held back to the 'ON' position the sound, as set by the SEND [SELECT] control, will be sent to the connected effects device. The indicator stays on in this mode to show that FX send is activated. When the switch is released, it will automatically return to the centre 'OFF' position.

FX SEND/RETURN RE-CONFIGURATION - to use INFADER with BPM effects units such as RED Sound - FEDERATION, XS-FX etc, the send/return configuration must be changed. These BPM effects processors rely on a continuous supply of audio for real-time BPM/tempo calculation which is fundamental to their operation and effectiveness [this also applies when you want to use the SEND as a record output].

If you want to use INFADER with BPM effects modules or the SEND as a record out, the configuration can be changed each time power is switched on. With power turned OFF, pull *and hold back* the [FX] paddle switch (momentary ON position). Turn the power ON at the rear panel and then after a few seconds release the [FX] paddle switch. The send output is now constantly active whilst the [FX] paddle switch controls the *return* signal (or AUX input) ON/OFF status - i.e the [FX] switch MUST now be set to 'ON' to hear the effects/auxiliary input.

RECORD OUT - If effects are not required, the SEND output can be used as a RECORD output. Simply connect your audio tape/CD recorder's input to the rear panel [SEND] sockets and adjust the output [LEVEL] / source [SELECT] accordingly.

NOTE: This special configuration setting is lost when power is turned off. If you use a BPM effects module or want to record a performance, always remember to hold the [FX] switch to ON before turning on the power.

MASTER / BOOTH OUTPUT

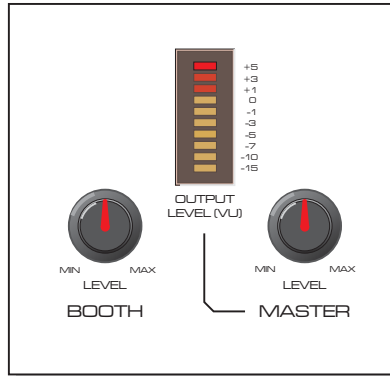

This section of INFADER features controls and indications for the master and booth outputs.

MASTER - LEVEL

This control adjusts the level of the master output volume on both the balanced and unbalanced outputs. At the fully anti-clockwise position there will be no sound. As the control is moved in a clockwise direction the output level will be gradually increased until, at the fully clockwise position, the output level will be at its maximum.

OUTPUT LEVEL [VU] METER

This indicator shows the master output volume in decibels from -15dB to +5dB. The indicators from -15 to 0dB are coloured green whilst the indicators from +1 to +5dB are coloured red to identify output overload conditions.

BOOTH - LEVEL

This control adjusts the level of the booth output volume. At the fully anti-clockwise position there will be no sound. As the control is moved in a clockwise direction the output level will be gradually increased until, at the fully clockwise position, the output level will be at its maximum. There is no level indicator for the booth output.

X-FADER CURVE

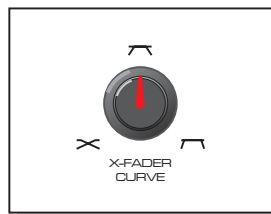

This section of INFADER features the crossfader curve control. The continuously variable crossfade characteristics are totally created and controlled by the DSP, which ensures perfect smoothness and precision for the ultimate crossfades.

At the fully anti-clockwise position [∞] the channel level will start to reduce at a linear rate near the crossfader centre position. As the control is moved in a clockwise direction the channel level will start to reduce more rapidly nearer the opposite channel end-stop [∩] until, at the fully clockwise position, the channel level will start to reduce dramatically just before the opposite channel end-stop [∩].

TRI-FADER MODULE

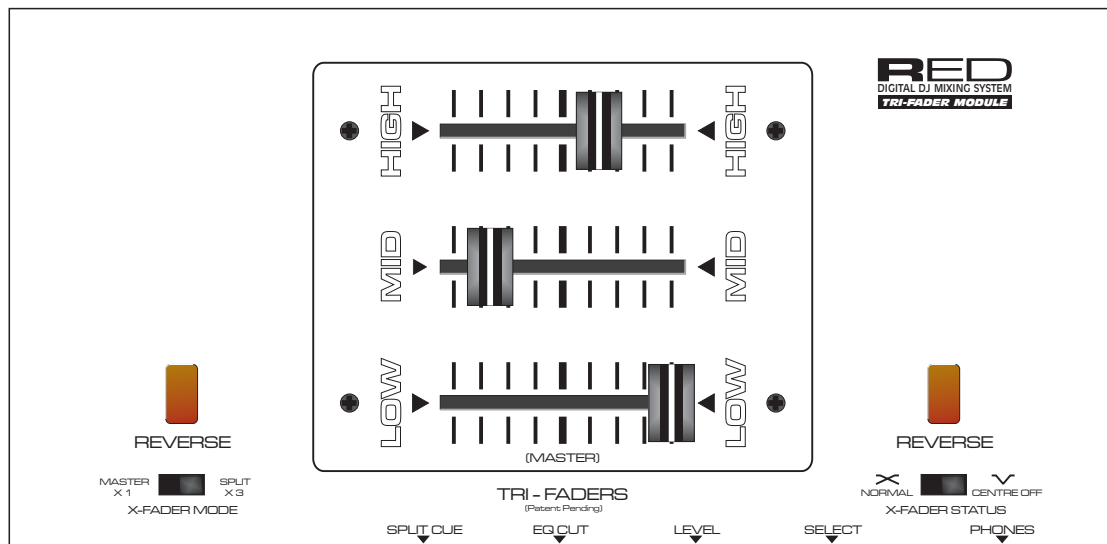

This section of INFADER is totally modular and features controls for the revolutionary TRI-FADER system. Each crossfader has its own dedicated high-order DSP filter for stunning, multi-way crossfades and being digitally controlled, they will not wear-out as fast as conventional analog faders.

HIGH CROSSFADER

When [X-FADER MODE] is set to [SPLIT x 3], this crossfader controls the HIGH frequency mix volume of channels 1&2. At the left-hand end-stop position only the CH1 high frequency sound will be heard. As the fader is moved towards the centre position the CH2 high frequency sound will be gradually introduced (how fast depends on the [X-FADER CURVE] control setting) until, at the centre position the CH1/CH2 high frequency sound will be of equal volume. As the fader is moved to the right, away from the central position, the CH1 high frequency sound will be gradually reduced until, at the right-hand end-stop the CH1 high frequency sound will be switched off.

The frequency band assigned to the [HIGH] fader is 2kHz to 20kHz.

When [X-FADER MODE] is set to [MASTER x 1], this crossfader has no function.

MID CROSSFADER

When [X-FADER MODE] is set to [SPLIT x 3], this crossfader controls the MID frequency mix volume of channels 1&2. At the left-hand end-stop position only the CH1 mid frequency sound will be heard. As the fader is moved towards the centre position the CH2 mid frequency sound will be gradually introduced (how fast depends on the [X-FADER CURVE] control setting) until, at the centre position the CH1/CH2 mid frequency sound will be of equal volume. As the fader is moved to the right, away from the central position, the CH1 mid frequency sound will be gradually reduced until, at the right-hand end-stop the CH1 mid frequency sound will be switched off.

The frequency band assigned to the [MID] fader is 150Hz to 2kHz.

When [X-FADER MODE] is set to [MASTER x 1], this crossfader has no function.

LOW [MASTER] CROSSFADER

When [X-FADER MODE] is set to [SPLIT x 3], this crossfader controls the LOW frequency mix volume of channels 1&2. At the left-hand end-stop position only the CH1 low frequency sound will be heard. As the fader is moved towards the centre position the CH2 low frequency sound will be gradually introduced (how fast depends on the [X-

FADER CURVE] control setting) until, at the centre position the CH1/CH2 low frequency sound will be of equal volume. As the fader is moved to the right, away from the central position, the CH1 low frequency sound will be gradually reduced until, at the right-hand end-stop the CH1 low frequency sound will be switched off.

The frequency band assigned to the [LOW] fader is 20Hz to 150Hz.

When [X-FADER MODE] is set to [MASTER x 1], this crossfader controls the OVERALL mix volume of channels 1&2, thereby acting as a normal crossfader. At the left-hand end-stop position only the CH1 sound will be heard. As the fader is moved towards the centre position the CH2 sound will be gradually introduced (how fast depends on the [X-FADER CURVE] control setting) until, at the centre position the CH1/CH2 sound will be of equal volume. As the fader is moved away from the central position the CH1 sound will be gradually reduced until, at the right-hand end-stop the CH1 sound will be switched off.

REVERSE SWITCHES

These push-button switches instantly reverse the CH1/2 crossfader settings in software. To operate the reverse function, press and hold either [REVERSE] button, as shown in the following example:

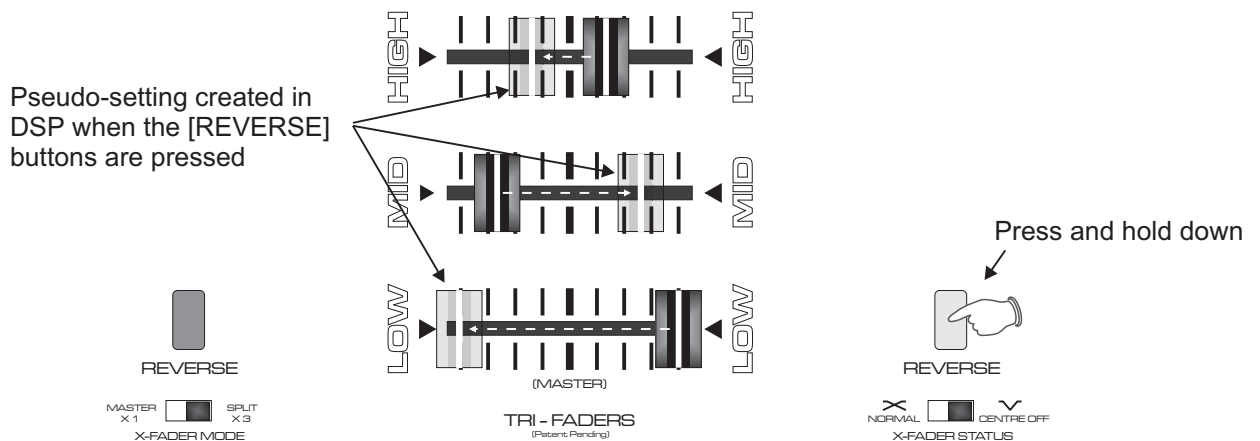

The output mix will be reversed only when the button is depressed. When the button is released, the output mix will instantly revert to the normal setting. The reverse function works in both [MASTER x 1] and [SPLIT x 3] modes.

NOTE: The [REVERSE] buttons are connected in parallel for convenient left / right-handed use - e.g. pressing either button will have the same effect.

X-FADER MODE SWITCH

This switch controls the crossfader split mode. When set to the [MASTER x 1] position, only the [LOW - MASTER] fader will be operational for standard crossfading. The [HIGH] and [MID] faders will be in-operative.

When set to the [SPLIT x 3] position, all three crossfaders will be operational for 3-way crossfading.

X-FADER STATUS SWITCH

This switch controls the fundamental operation of the crossfaders. When set to the [> NORMAL] position, the crossfader mix characteristics will be standard - e.g. the CH1 mix volume will be maximum at the left end-stop position and minimum (off) at the right end-stop position therefore, both CH1 and 2 sound will be mixed equally at the centre position.

When set to the [< CENTRE OFF] position, the crossfader mix characteristics will be changed. In this mode, the mix volume of CH1 & 2 will be at minimum (off) at the CENTRE position - e.g. the CH1 mix volume will be maximum at the left end-stop position and minimum (off) at the centre position therefore, both CH1/ 2 sound will be OFF at the centre position.

This new feature allows you to totally cut the CH1/2 sound on one or more crossfaders simply by moving them to the centre position.

HEADPHONE MONITOR

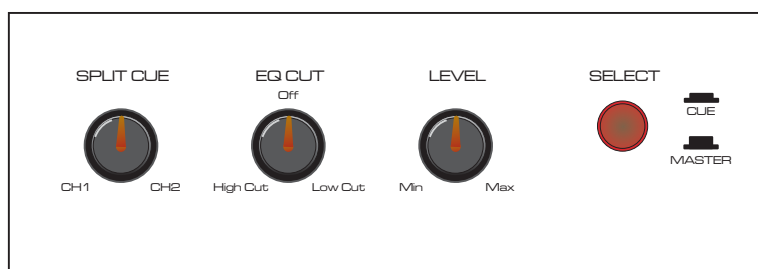

This section of INFADER features all the headphone monitoring controls which again, come under the control of the DSP. This allows the inclusion of a special cue EQ control which filters-out unwanted frequencies, letting you tune-in to defined elements within the sound and create a perfect mix.

LEVEL

This control adjusts the output level to the connected headphones. At the fully anti-clockwise position there will be no sound. As the control is moved in a clockwise direction the output level will be gradually increased until, at the fully clockwise position, the output level will be at its maximum.

MASTER/CUE SELECT

This switch selects the monitor signal source. When the switch is OUT, the monitor output sound will be derived from the master output buss. In this mode the [EQ CUT] and [SPLIT CUE] controls have no function. When the switch is pressed IN, the monitored sound will be derived from the CUE section. The [EQ CUT] and [SPLIT CUE] controls will now operate as described below:

EQ CUT

When [MASTER/CUE SELECT] is set to CUE this control adjusts the tone of the monitored sound, cutting the highs or lows about the centre off position. At the 12 o'clock centre click position the EQ will be flat (no cut). As the control is moved anti-clockwise the HIGHER frequencies will be progressively cut until, at the fully anti-clockwise position the maximum high frequency cut will be applied (-85dB). As the control is moved clockwise from the centre position the LOWER frequencies will be progressively cut until, at the fully clockwise position the maximum low frequency cut will be applied (-85dB).

When [MASTER/CUE SELECT] is set to MASTER this control has no function.

SPLIT CUE

When [MASTER/CUE SELECT] is set to CUE this control adjusts the relative mix balance between CH1 and CH2. At the fully anti-clockwise position only CH1 sound will be audible. As the control is moved anti-clockwise the CH2 sound will be gradually introduced until, at the 12 o'clock position, CH1 and CH2 sound will be equal. As the control is moved clockwise from the centre position the CH1 sound will gradually reduce until, at the fully clockwise position only CH2 sound will be audible.

When [MASTER/CUE SELECT] is set to MASTER this control has no function.

REMOVING THE MODULE

The front panel section of INFADER is fully modular and can be interchanged with a range of multi-function designs.

NOTE: Under normal circumstances we recommend that the module should be left in place to avoid any unnecessary damage to delicate internal circuitry.

IMPORTANT SAFETY NOTE! before attempting to remove the module section, ensure all power is turned off and power leads are disconnected from the rear panel.

To remove the module section, first un-screw the four top panel fixing screws ('1pt pozi-drive' type) and remove the front panel headphone jack support nut, as shown in the following example:

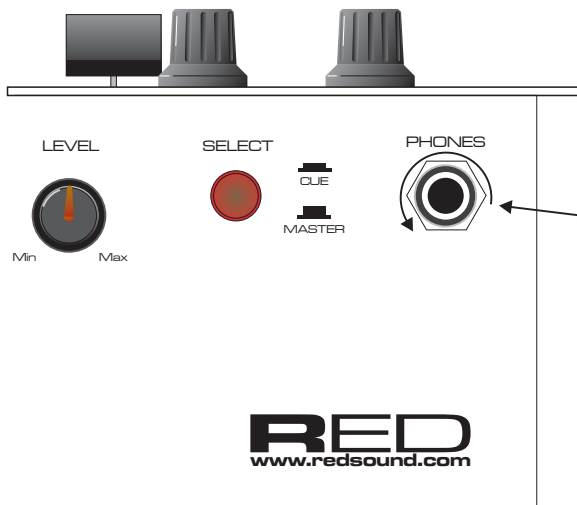
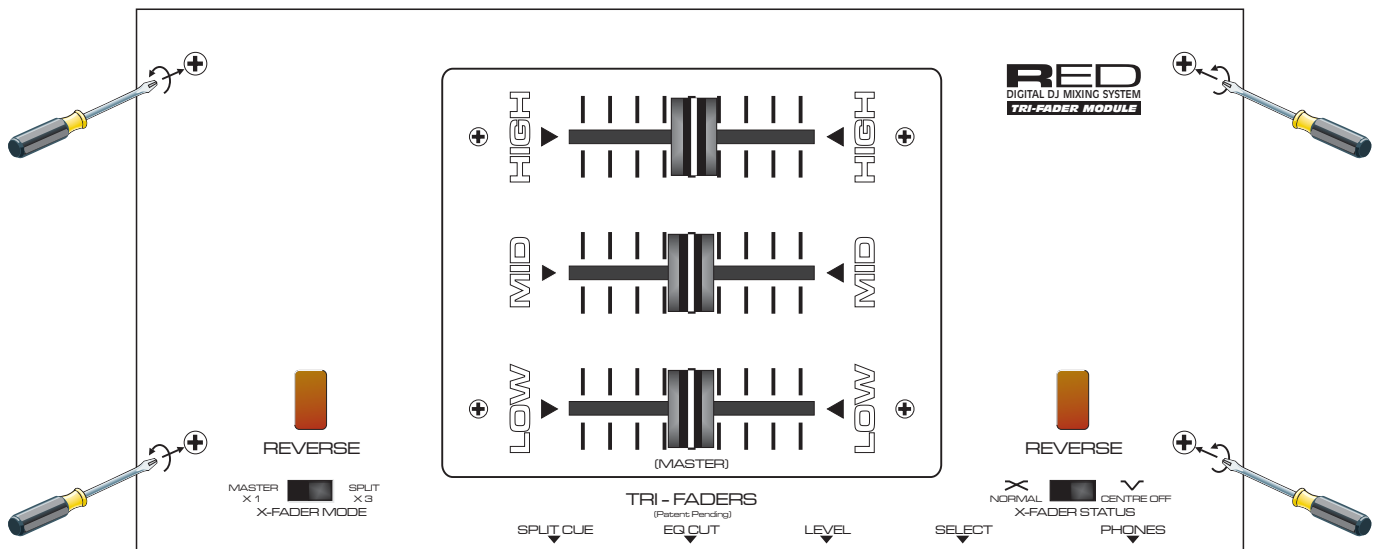

Remove support nut (turn anti-clockwise). This is factory-fit finger tight so special tools should not be required.

THE MODULE

Keep the screws/nut in a safe place for re-assembly. The module can now be separated from the main chassis.

With INFADER facing you (as it would under normal operating conditions), hold the module panel near the top left and right corners and then carefully lift upwards and towards you at an angle until it reaches about 15-20 degrees, as shown in the following diagrams:

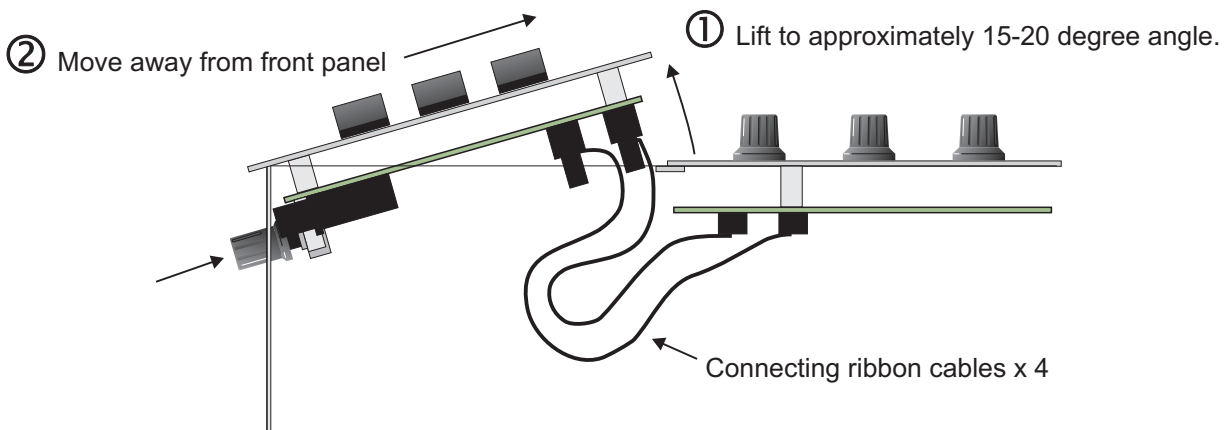
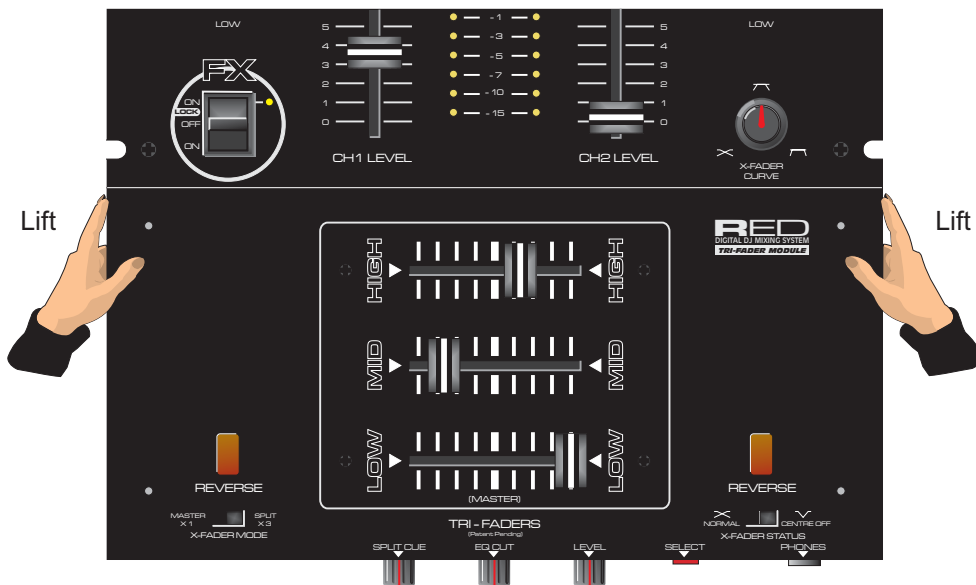

When this angled position is reached, start to move the module panel away from you, just enough so as to clear the front panel control knobs, switch and socket from the front casing. This will release the module from the main chassis allowing you to bring the panel into an upright position for easy cable dis-connection.

INFADER features two printed circuit boards (PCB's), one situated in the main chassis and the other attached to the module. The PCB's are connected by four ribbon cables which carry vital digital/analog signals between the two sections therefore, they must be treated with extreme care and attention. The length of the cable allows plenty of room to manouevre the module section without straining any connections.

AVOID STRAINING THE CABLES WHILST REMOVING/INSTALLING MODULES!

There are two pairs of cables positioned to the extreme left and right side of the PCB (to avoid cross-connections). Each pair consists of 1 x 10-way and 1 x 26-way ribbon cable. Each ribbon cable has a quick-release plug/socket connection on the back of the PCB, which should now be visible and fully accessible for dis-connection.

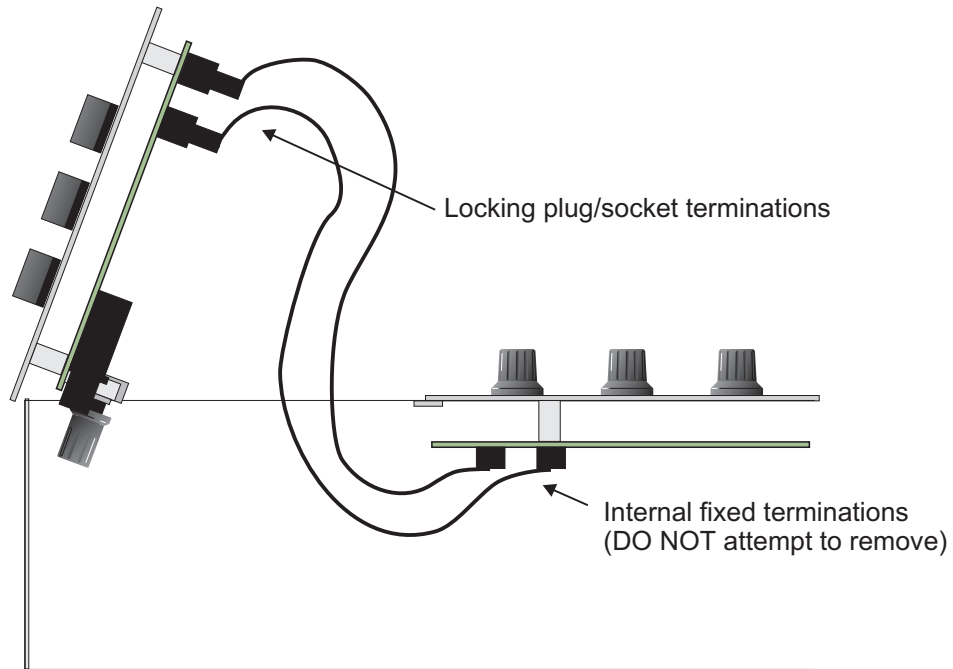

To unlock the termination, snap-back the two locking arms, as shown in the following diagram:

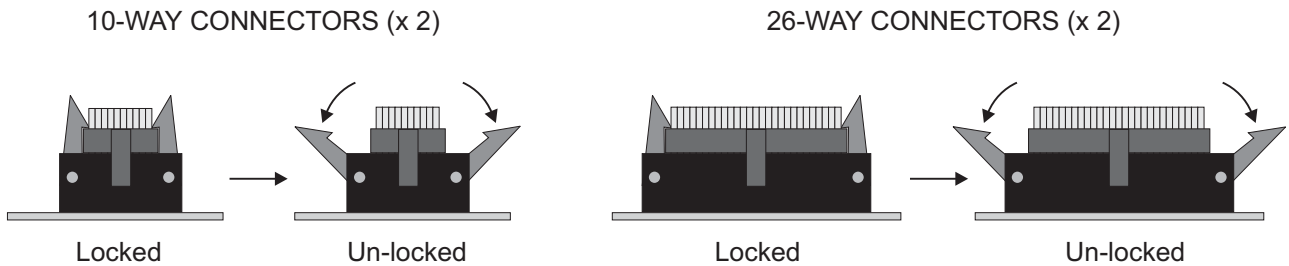

Once the locking arms have been released the plugs can be removed from the sockets. Hold the cable end as close to the plug as possible and then pull away gently in a 90 degree direction to the PCB, as shown in the following diagram:

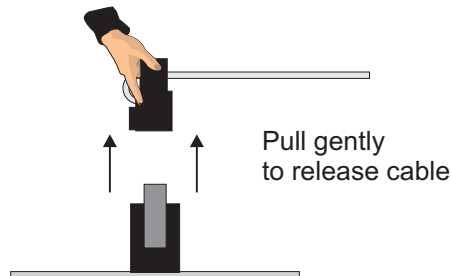

The module section should now be free from the main chassis and ready for storage.

DO NOT TOUCH MODULE PCB/COMPONENTS AND AVOID STATIC CONDITIONS!

STORE MODULE IN IT'S BOX AWAY FROM EXCESSIVE HEAT/COLD/MOISTURE AND MAGNETIC FIELDS!

FITTING THE MODULE

IMPORTANT SAFETY NOTE! before attempting to fit a new module section, ensure all power is turned off and power leads are disconnected from the rear panel.

To fit a module section, rest the panel in an upright position with the front panel controls just inside the edge of the main chassis ready to accept the ribbon cables, as shown in the following example:

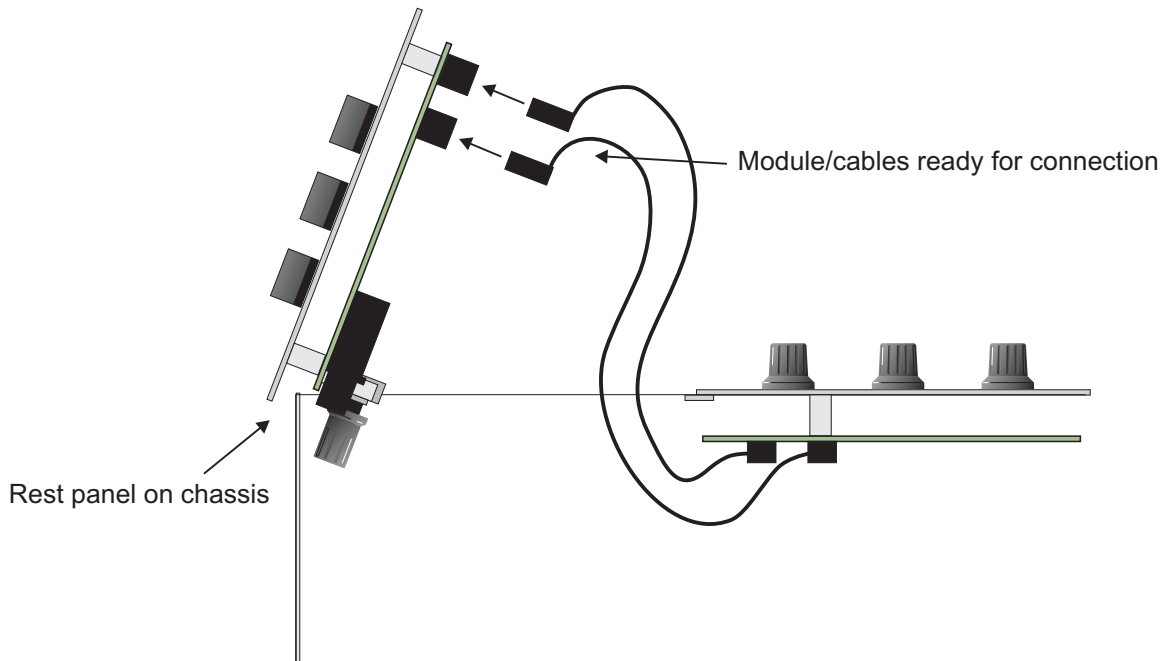

Before attempting to connect the ribbon cables, observe the correct polarity of the plug/sockets, as shown in the following diagram:

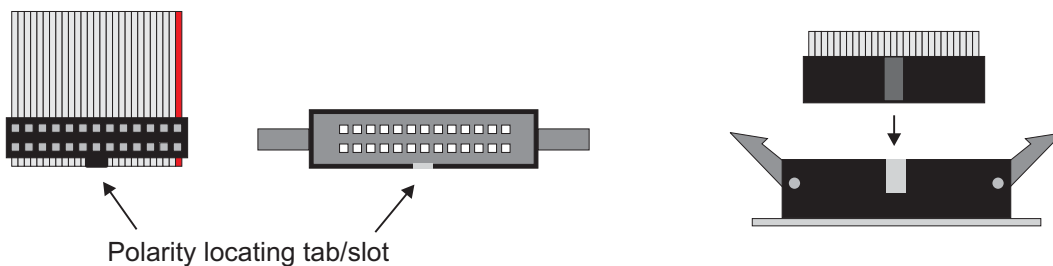

These tabs make it impossible to reverse the polarity of the connectors.

IMPORTANT: DO NOT ATTEMPT TO FORCE FIT PLUGS - CHECK POLARITY!

IMPORTANT: ENSURE THE LEFT/RIGHT PAIRS OF CABLES ARE NOT CROSSED-OVER!

When you have correctly identified the corresponding cables/connectors, press the plug-end of each ribbon cable firmly into the correct 10 and 26-way socket on either side of the PCB, closing the snap-shut latching tabs. When you are satisfied that all connections are secure the module section can be offered back to the main chassis following a reversal of the removal procedure, as shown in the following diagrams:

As the panel is lowered into the main chassis it may be necessary to guide the ribbon cables downwards to avoid trapping between the panels.

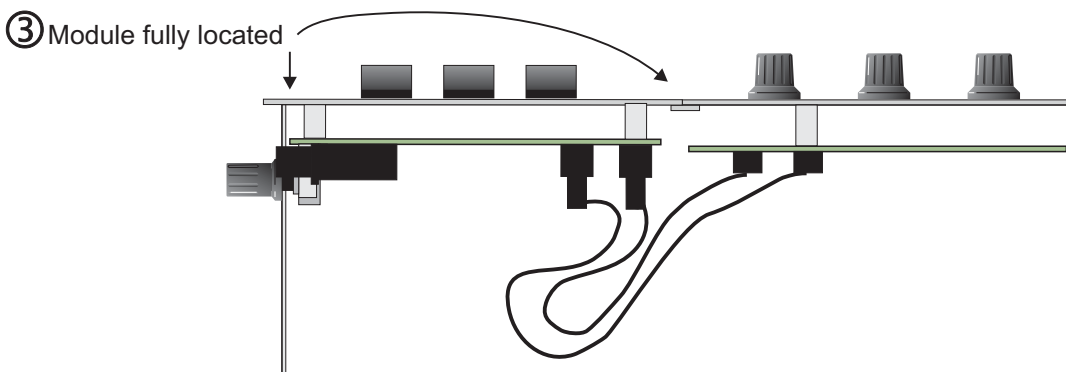
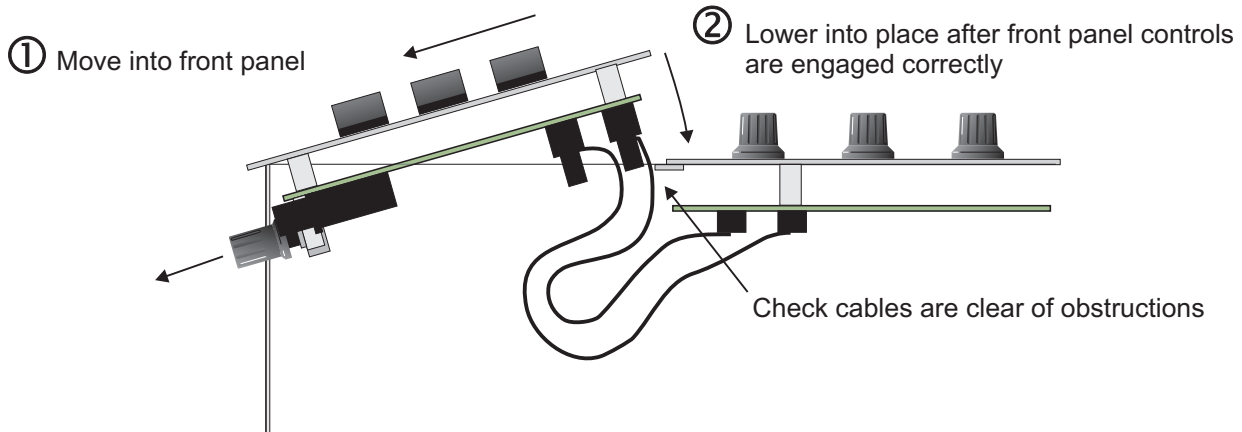

Before replacing the fixings, temporarily apply power to INFADER to check for normal operation.

When you are satisfied that the module has been installed successfully, turn the power OFF and then re-fit the four top panel fixing screws and front panel headphone jack support nut.

INFADER is now ready for use.

REPLACING THE CROSSFADERS

The crossfader volume controls can be replaced if performance is affected due to wear or damage. In the TRI-FADER module, all three crossfaders are mounted on a single circuit card for easy replacement.

To replace the crossfaders, you must first remove the module section following the instructions detailed on pages 18 thru 20.

Once the module has been separated from the main chassis, pull-off the crossfader knobs and remove the connector from the rear of the PCB, as shown in the following diagrams:

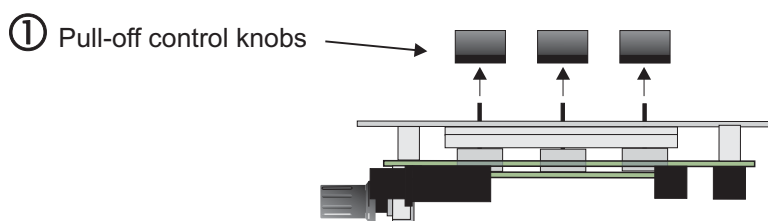

② Disconnect plug from socket

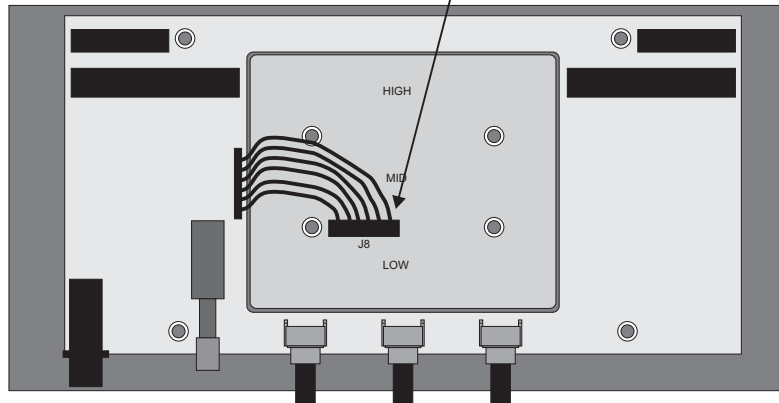

To remove the complete crossfader assembly, simply un-screw the four front panel screws situated on either side of the crossfaders, as shown in the following diagram:

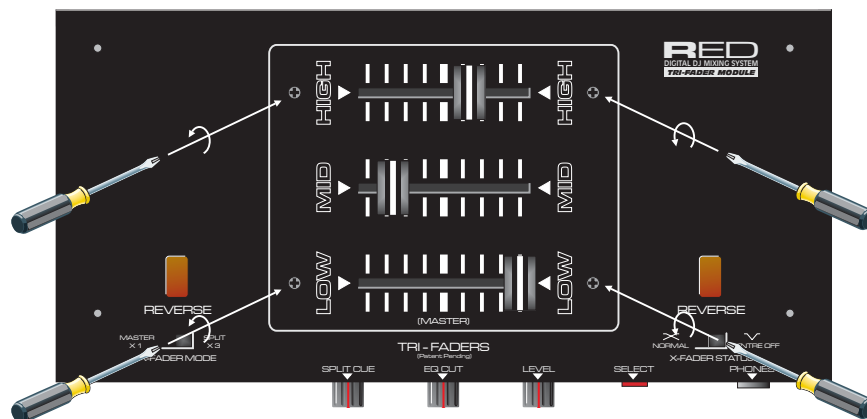

Hold the back of the crossfader assembly to support it as the last screws are removed. Gently bring away the crossfader panel, angling it slightly to clear the main PCB and taking care not to damage the PCB or associated components when the metal support frame clears the aperture, as shown below:

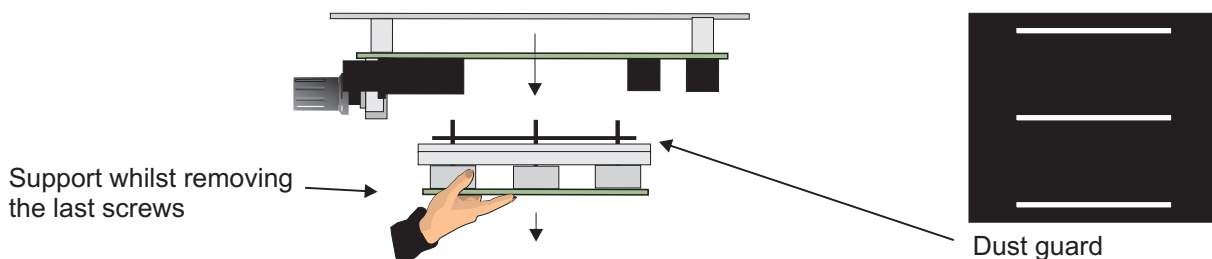

Hold the crossfader assembly with the metal support bracket uppermost, lift-off the black dust guard and then remove the six fader fixing screws, keeping them all in a safe place ready for re-assembly, as shown in the following diagrams:

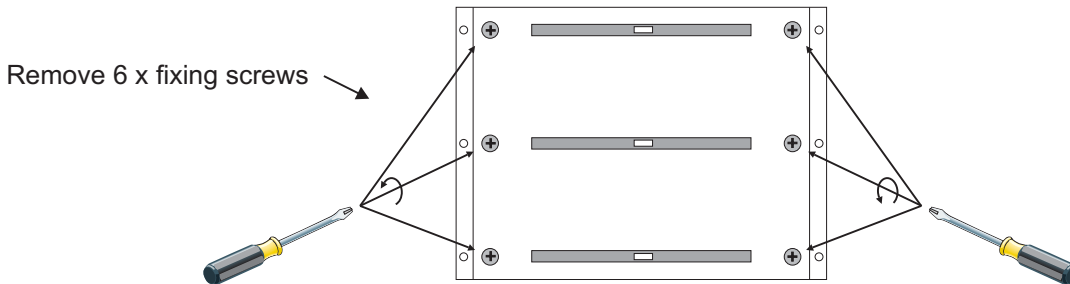

Fitting the new crossfader assembly:

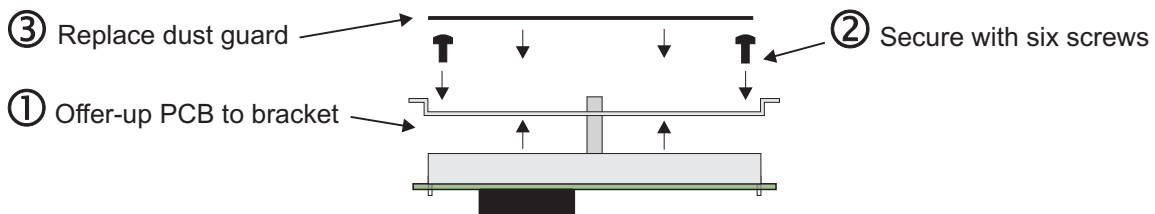

The new crossfader assembly is now ready to re-install in the module following a reversal of the removal procedure detailed previously.

IMPORTANT! do not use screws other than those supplied. Screws with a longer length WILL DAMAGE the fader tracks.

IMPORTANT! Observe the correct PCB orientation before re-fitting the crossfader assembly.

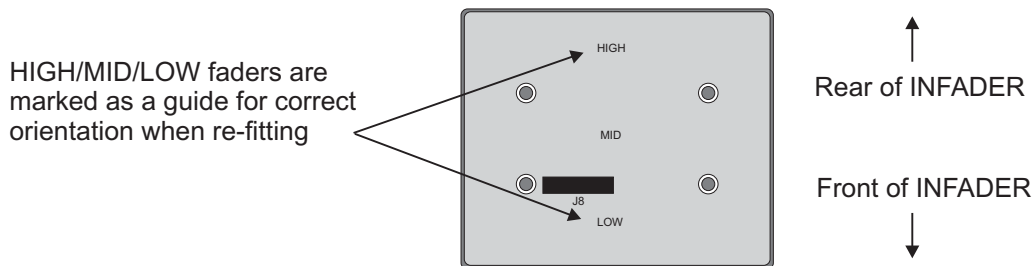

TROUBLESHOOTING

Problem

No Power

Check

Check power supply connection
Check internal cable connections between main PCB and module PCB

No sound

Check position of input controls: SELECTOR / TRIM / LEVEL / EQ CUT
Check input connections
Check crossfader STATUS setting (centre off?)
Check FX ON/OFF is set to off and-or send/return routing is correct [shorting bars!]
Check crossfader settings
Check output levels/connections

Noise

Check and adjust back input TRIM controls
Check and adjust back output level controls
Check analog player ground connections

No TRI- FADERS

Check crossfader MODE setting (master?)
Check internal cable connections

SPECIFICATION

DIGITAL AUDIO:

Sample rate: 44.1kHz
Conversion rate: 16 bit

FREQUENCY RESPONSE:

CD/Line: 20 Hz to 20 kHz (+/- 0.5 dB)
Phono: 20 Hz to 20 kHz (+/- 1.5 dB/RIAA)
MIC [Line]: 20 Hz to 20 kHz (+/- 2 dB) [20 Hz to 20 kHz (+/- 0.5 dB)]
AUX/FX Return: 20 Hz to 20 kHz (+/- 0.5 dB)

SIGNAL/NOISE RATIO:

CD/Line: 90 dB
Phono: 75 dB
MIC [Line]: 70 dB [90 dB]
AUX/FX Return: 90 dB

TOTAL HARMONIC DISTORTION / CROSSTALK:

THD: less than 0.02%
Crosstalk: 80dB

AUDIO INPUT: (level/impedance)

CD/Line: -14dBV / 22k ohms
Phono: -54dBV / 47k ohms
MIC [Line]: -54dBV / 3k ohms [-14dBV / 22k ohms]
AUX/FX Return: -14dBV / 22k ohms

AUDIO OUTPUT: (level/impedance)

Master unbalanced: 0dBV / 1k ohms
Master balanced(XLR): 4dBm / 600 ohms
Booth monitor: 0dBV / 1k ohms
MIC insert: 0dBV / 1k ohms
FXSend: 0dBV / 1k ohms
Headphones: -4dBV / 22 ohms

CHANNEL EQ:

High: +4 dB/ -85 dB (10kHz)
Mid: +4 dB/ -85 dB (1kHz)
Low: +2 dB/ -85 dB (100Hz)

POWER SUPPLY:

External switch mode type (16VDC 750mA minimum) output plug wired centre pin +.

DIMENSIONS/WEIGHT:

350(H)x236(W)x76(D)mm 4kg

OPTIONAL ACCESSORIES:

Replacement modules - see catalogue or ask your main dealer / distributor for details.